



ENDURANCE SERIES

## Light Duty Commercial Electric Water Heater

6–55 gallon capacity, up to 12 kW, single phase and three phase options available

HydraStone™ cement lining provides longer tank life

High impact composite jacket eliminates damage during transit and installation and cannot rust or corrode

Copper-silicon tappings cannot rust or corrode

- Polyurethane foam insulation reduces heat loss
- Built-in heat trap lowers operating costs
- DOE compliant
- Full five (5) year Non Pro-Rated tank warranty is standard
- Full ten (10) year Non Pro-Rated tank warranty can be specified for extended protection

### Applications

Office buildings, schools, hospitals, industrial facilities, hotels, and much more.



### A long lasting, trouble-free water heater

The Hubbell Endurance E water heater has a number of features not found in other conventional heaters making it better suited to resist the corrosive effects of hot water. The heart of the Endurance E is a superior storage vessel with HydraStone™ cement lining, solid copper-silicon threaded tank openings and a built-in heat trap, all of which ensure a longer lasting and energy efficient water heater.

### Over 100 years of water heating expertise

Hubbell water heaters are the right choice for your commercial and industrial applications. We have water heating solutions for most energy sources with storage capacities from 1–10,000 gallons — all designed, engineered, and manufactured for reliability and longevity coupled with unparalleled support and service.

ASME option available.



## The Difference: HydraStone™ Cement Lining

**Cement lined tanks offer significant longevity, trouble-free operation and a lower lifetime cost.**

**The type of protective lining** is the single most important feature when determining the quality of any water heater. The ability of a lining to protect the steel tank is primarily based on its thickness and complete coverage of all steel surfaces.

**A glass lined tank uses only  $\frac{5}{1000}$  inches of glass (the thickness of a sheet of paper)** which does not cover all internal surfaces. To compensate, all glass lined tanks require a sacrificial anode rod which must be periodically inspected and replaced.

**Our tanks are lined with a minimum of  $\frac{1}{2}$  inches of high density HydraStone cement – 100 times thicker than glass lining.** Full coverage is achieved by injecting the precise amount of HydraStone cement into each tank and then centrifugally spinning it at 250 RPM to ensure complete and uniform coverage. This process provides maximum protection from the corrosive effects of hot water. Additionally, cement lined tanks do not require a sacrificial anode, eliminating periodic inspections and replacement costs associated with glass lined tanks.

**Our water heater tanks are constructed with solid non-ferrous copper-silicon tank tappings** which are impervious to the corrosive effects of hot water. Glass-lined tanks have steel tappings which are vulnerable to corrosion.

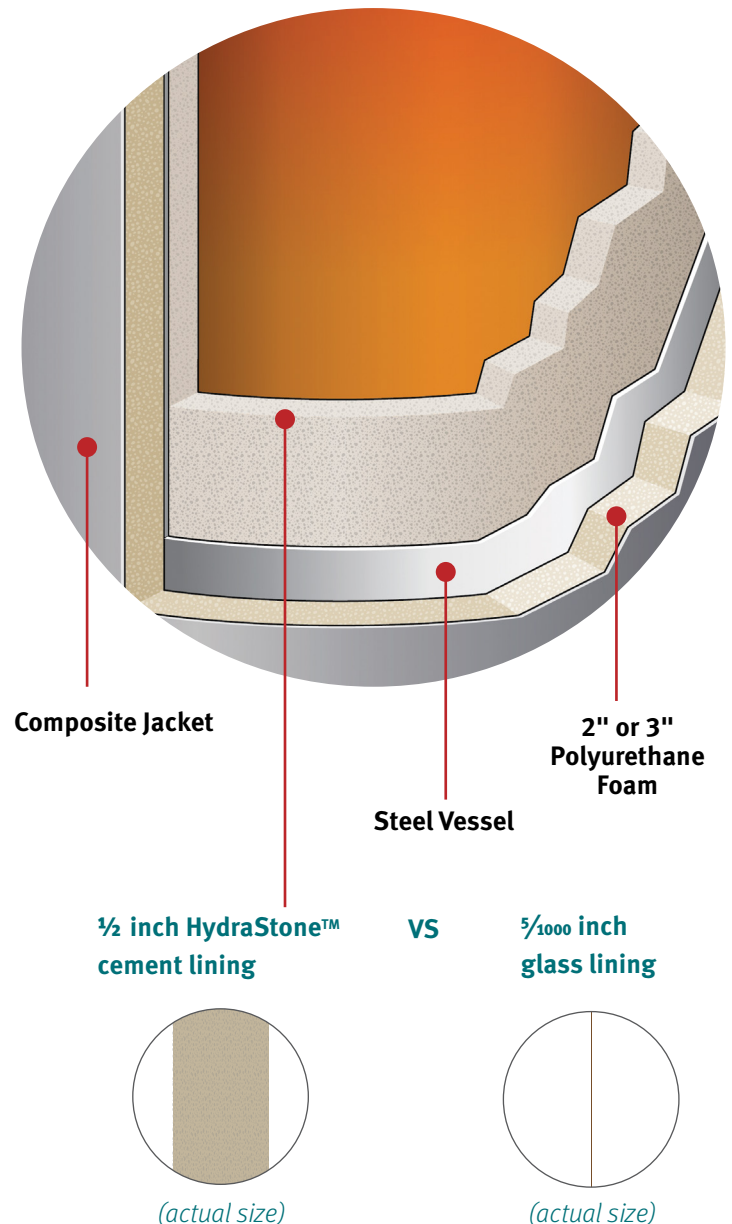

## Heater Specifications

<b>Tank</b>	HydraStone Cement Lined Steel
<b>Volumes</b>	6, 10, 19, 30, 40 and 55 gallons
<b>Orientation</b>	Vertical, horizontal option available
<b>Voltages</b>	120–480 Volt
<b>Phases</b>	1Φ or 3Φ
<b>Inlet Size</b>	3/4" Female NPT
<b>Outlet Size</b>	3/4" Male NPT
<b>Drain Size</b>	3/4" GHT
<b>Relief Valve Size</b>	3/4" Female NPT
<b>Relief Valve Type</b>	T&P, 210°F, 150 psi
<b>Thermostat Range</b>	110–170°F (surface)
<b>Hi-Limit</b>	190°F Manual Reset
<b>Design WP</b>	150 psi
<b>Design TP</b>	300 psi
<b>Elements</b>	
1Φ or 3Φ open delta	Copper sheathed
3Φ balanced	Incoly sheathed
<b>Insulation</b>	<ul style="list-style-type: none"> <li>• 3" Polyurethane Foam</li> <li>• 2" Polyurethane Foam for 6, 10, and 19 gallon tanks</li> </ul>
<b>Tank Warranty</b>	
<b>Standard</b>	5 year Non Pro-Rated
<b>Optional</b>	10 year Non Pro-Rated
<b>Electrical Warranty</b>	1 Year
<b>Jacket</b>	High Impact Colorized Composite
<b>Finish</b>	White with Black Trim

Under counter/low boy sizes available – see chart on page 4.

For horizontal ceiling hung or floor mounted see Endurance [EH/SEH brochure](#).

## Standard Features

### Tank

The Hubbell Endurance E tank is welded heavy steel construction designed for 150 psi working pressure and tested to 300 psi. All tank openings are non-ferrous solid copper-silicon and are resistant to the corrosive effects of hot water.

### Plumbing

A 3/4" combination cold water inlet and drain, with non-corrosive strata flow diffuser which prevents incoming cold water from mixing too rapidly with the hot water in the tank and assures delivery of more hot water – not lukewarm water.

A 3/4" hot water outlet with a uniquely designed built-in heat trap prevents heated water from radiating through the piping during standby periods.

### Electrical

Copper sheathed (single phase or three phase open delta) or incoly sheathed (three phase balanced) immersion heating elements with low watt density for prolonged life – up to 10 kW in 120, 208, 240, 277, 480 volt single phase and 3 phase (see chart for details). An adjustable surface thermostat operates in 110–170°F range. Integral hi-limit with manual reset button for over-temperature protection is factory set at 190°F. Single phase upper and lower element configurations are factory wired for non-simultaneous operation. Three phase are wired for simultaneous operation.

### Insulation

Meets the new NAECA III efficiency requirements. Highly efficient polyurethane foam insulation meets or exceeds the requirements of ANSI/ASHRAE/IESNA 90.1–2007 standards for energy efficiency and heat loss. Insulation R value = 7.2/inch

### Jacket

The exterior protective jacket is constructed from composite material which cannot rust or corrode and does not require painting.

# Dimensions

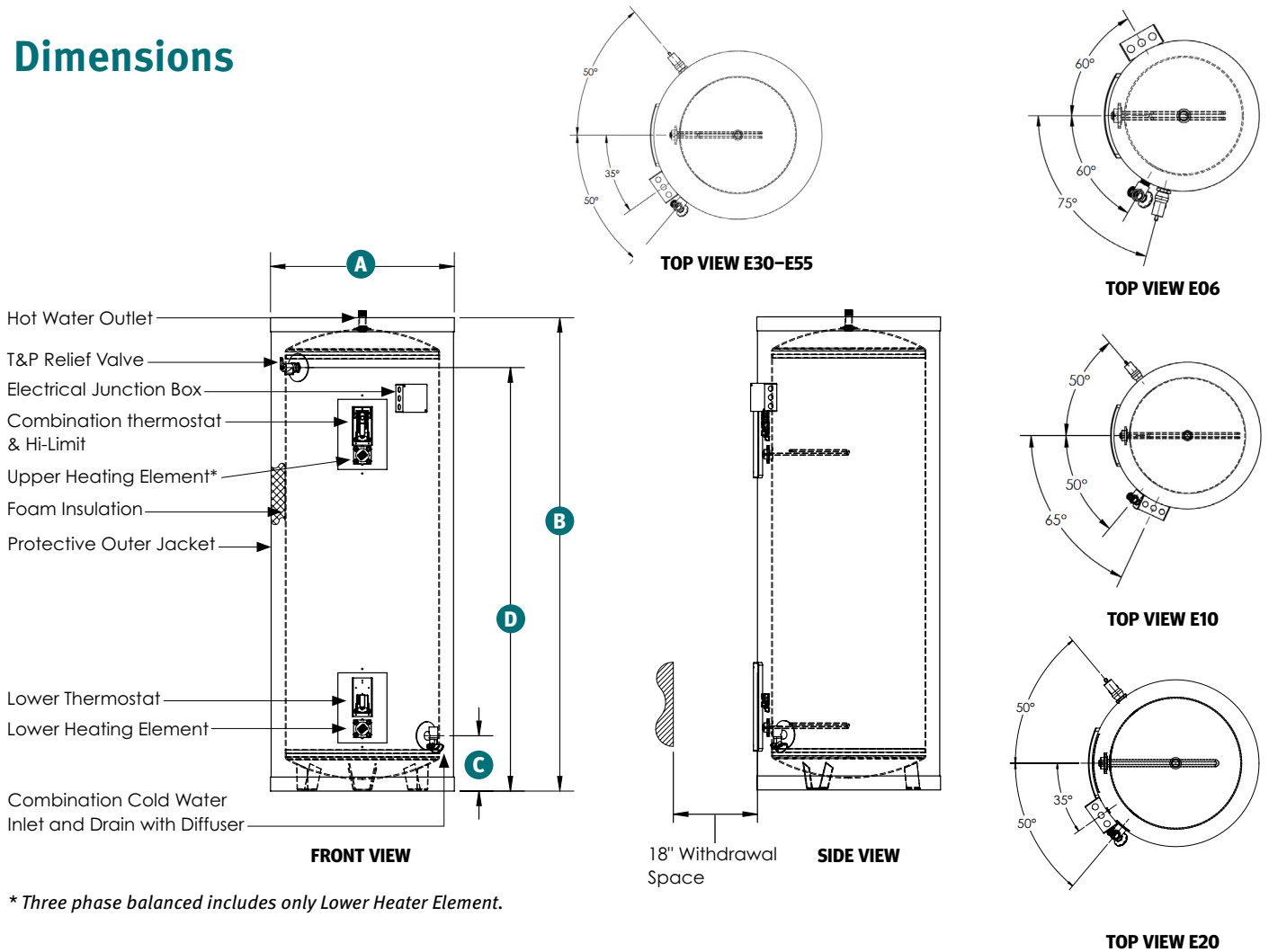

\* Three phase balanced includes only Lower Heater Element.

## Endurance E Dimensional Data

Storage Capacity (Gallons)	Base Model Number	Standard Configurations		Dimensions (inches)				Shipping Weight (lbs.)
		kW	Volts 1Φ	Overall Diameter "A"	Overall Height "B"	Floor to Inlet "C"	Floor to T&P "D"	
6	E06	1.5	120, 240	15	18.0625	6.125	12.875	105
10	E10	1.5	120, 240	20	21.5	7.5	14.75	120
19	E20	1.5	120, 240	20	32.75	7.5	26.75	150
30	E30	4.5	240	22.75	41.625	7.5	34.25	225
40	E40	4.5	240	22.75	57.25	7.5	50	240
55	E55	4.5	240	25	59.25	7.875	50.875	375
30	E30U	4.5	240	25	34.25	7	24	205
40	E40U	4.5	240	28	31.75	7	24	270
50	E50U	4.5	240	30	37.25	7	27	300

Under counter options

### Notes:

- 120 volt models are available in 1500, and 2500 Watts only.
- The 6, 10, and 19 gallon models are available in lower element design only and come standard with 2" insulation. All other sizes have both upper and lower element banks of identical wattage and are wired for non-simultaneous operation and come standard with 3" insulation.
- 6 gallon available in single phase only.
- For under counter models E30U, E40U, and E50U the hot water outlet is located on the side.

All information is subject to change without notice. Consult factory for submittal drawings.

## kW and Amperage Selection Charts

**Note:** 1 kW will heat 4.1 GPH at 100°F rise

### 6 Gallon kW and Amperage (Amperage shown in chart below indicates available models)

SINGLE ELEMENT	kW	Recovery (GPH)	1 Phase Voltages				
			120	208	240	277	480
1	4			5		4	
1.5	6	13			6		3
2	8			10		7	4
2.5	10	21		12	10		
3	12			14	13		6
3.5	14			17	15	13	
4	16			19	17	14	
4.5	18				19		
5	21					21	10
6	25						13

XX = Amperages shown in red use an Immersion Thermostat, all others use a Surface Thermostat



### 10 and 20 Gallon kW and Amperage Chart (Amperage shown in chart below indicates available models)

SINGLE ELEMENT	kW	Recovery (GPH)	1 Phase Voltages					3 Phase Voltages – Balanced (lower element only)		
			120	208	240	277	480	208	240	480
1	4			5	4	4				
1.5	6	13		7	6	5	3			
2	8	17		10	8	7	4	6		
2.5	10	21		12	10	9	5			
3	12			14	13		6	8	7	
3.5	14			17	15	13	7			
4	16			19	17	14	8	11	10	5
4.5	18			22	19	16	9			
5	21			24	21	18	10	14	12	6
6	25			29	25	22	13	17	14	7
8	33			38	33	29		22	19	10
10	41				42	36			24	12

☐ Contactor Required      XX = Amperages shown in red use an Immersion Thermostat, all others use a Surface Thermostat

All information is subject to change without notice. Consult factory for submittal drawings.

**30 Gallon kW and Amperage Chart** *(Amperage shown in chart below indicates available models)*

kW	Recovery (GPH)	1 Phase Voltages (Dual element non-simultaneous standard)					3 Phase Voltages (Single element balanced with contactor(s))			3 Phase Voltages (Dual element simultaneous open delta)		
		120	208	240	277	480	208	240	480	208	240	480
1	4		5	4	4							
1.5	6	13	7	6	5	3						
2	8	17	10	8	7	4	6	5		8	7	
2.5	10	21	12	10	9	5						
3	12		14	13		6	8	7		13	11	5
3.5	14		17	15	13	7						
4	16		19	17	14	8	11	10	5	17	14	7
4.5	18		22	19	16	9						
5	21		24	21	18	10	14	12	6	21	18	9
6	25		29	25	22	13	17	14	7	25	22	11
7	29									29	25	13
8	33		38*	33*	29*		22	19	10	33	29	14
9	37									37	32	16
10	41			42*	36*			24	12	42	36	18
12	49									50	43	22

\* Single element only    **XX** = Amperages shown in red use an Immersion Thermostat, all others use a Surface Thermostat

**40 and 55 Gallon kW and Amperage Chart** *(Amperage shown in chart below indicates available models)*

kW	Recovery (GPH)	1 Phase Voltages (Dual element non-simultaneous standard)					3 Phase Voltages (Single element balanced with contactor(s))			3 Phase Voltages (Dual element simultaneous open delta)		
		120	208	240	277	480	208	240	480	208	240	480
1	4		5	4	4							
1.5	6	13	7	6	5	3						
2	8	17	10	8	7	4	6	5		8	7	
2.5	10	21	12	10	9	5						
3	12		14	13		6	8	7		13	11	5
3.5	14		17	15	13	7						
4	16		19	17	14	8	11	10	5	17	14	7
4.5	18		22	19	16	9						
5	21		24	21	18	10	14	12	6	21	18	9
6	25		29	25	22	13	17	14	7	25	22	11
7	29									29	25	13
8	33		38*	33*	29*		22	19	10	33	29	14
9	37									37	32	16
10	41			42*	36*			24	12	42	36	18
12	49									50	43	22

\* Single element only    **XX** = Amperages shown in red use an Immersion Thermostat, all others use a Surface Thermostat

All information is subject to change without notice. Consult factory for submittal drawings.

## Endurance E Model Number Designation 6, 10, and 20 Gallon

MODEL	MODEL NUMBER	STYLE	See charts on pages 5 & 6		TANK	See charts on pages 5 & 6		
			LOWER KW*			VOLTAGE / PHASE	OPTIONAL EQUIPMENT	
<b>E</b> 2" Foam Insulation	6	<i>Leave blank for standard</i> <b>A = ASME</b>	1		<b>SL</b> = HydraStone cement lined tank	<b>A</b> = 120/1 <b>RS</b> = 208/1 <b>S</b> = 240/1 <b>W</b> = 277/1 <b>T4S</b> = 480/1 <b>Balanced 3Φ and 3Φ open delta**</b> <b>R</b> = 208/3 <b>T</b> = 240/3 <b>T4</b> = 480/3	Write/type optional equipment code in the gray box below in alphabetical order. For multiple options separate codes with a dash (-). Available options are on page 8.	
	10		1.5					<b>CN</b> = Solid copper-nickel tank
	20		2					
			3		<b>SS</b> = Stainless steel 316L			
			3.5					
			4					
			4.5					
			5					
			6					

E

\* 6, 10 and 20 gallon models are lower element only

\*\* 10 and 20 gallon available in 3 phase balanced only

## Endurance E Model Number Designation 30–55 Gallon

MODEL	MODEL NUMBER	STYLE	See charts on pages 5 & 6		TANK	See charts on pg. 5 & 6		
			UPPER KW	LOWER KW		VOLTAGE / PHASE	OPTIONAL EQUIPMENT	
<b>E</b> 3" Foam Insulation	30	<i>Leave blank for standard</i> <b>A = ASME</b> <b>U</b> = Under counter <i>Available in 30, 40 and 50 gallon sizes only</i>	0**	1	<b>SL</b> = HydraStone cement lined tank	<b>A</b> = 120/1 <b>RS</b> = 208/1 <b>S</b> = 240/1 <b>W</b> = 277/1 <b>T4S</b> = 480/1 <b>Balanced 3Φ and 3Φ open delta</b> <b>R</b> = 208/3 <b>T</b> = 240/3 <b>T4</b> = 480/3	Write/type optional equipment code in the gray box below in alphabetical order. For multiple options separate codes with a dash (-). Available options are on page 8.	
	40		1.5	1.5				<b>CN</b> = Solid copper-nickel tank
	55		2	2				
			3	3	<b>SS</b> = Stainless steel 316L			
			3.5	3.5				
			4	4				
			4.5	4.5				
			5	5				
			6	6				
				7				
				8				
				9				
				10				
		12						

E

\*\* Upper kW "0" is only available in balanced 3 phase

### Example: E55A-4.5-4.5SLS-C1-V10

Model E with 3" foam insulation storage tank of 55 gallons, ASME certified, with 4.5 kW upper and lower heating elements, HydraStone cement lined steel storage tank, 240 V, single phase, 60 Hz power. Includes optional immersion thermostat and optional 1-1/2" MALE NPT inlet/outlet.

All information is subject to change without notice. Consult factory for submittal drawings.

## Optional Equipment

**Note:** *Optional equipment must be called out in the written specifications, use the codes below.*

### Controller

- C1** Immersion thermostat specify 100–190°F
- C2** Low range immersion thermostat (30-110°F range)
- C3** Immersion adjustable 100–240°F safety hi-limit cut out with manual reset
- C6** Off-peak wiring for load management savings
- C30** Heating elements wired for simultaneous operation
- C35** T1000 digital controller with BACnet communication module

### Electrical

- E5** Three phase open delta wiring (must be simultaneous operation; reference 3 phase kW selection charts on previous pages)

**Note:** Alternate voltages available including 380, 415, 440 and 600 volt, please consult factory

### General

- G1** Combination temperature and pressure gauge: 2.5" dial, 70-250°F, 0-200 psi mounted tank

### Vessel

- V10** 1-1/2" Male NPT inlet and outlet water connections
- V15** Additional 3/4" FNPT tapings
- V16** Additional 1-1/2" FNPT tapings
- V20** Integrally welded seismic attachment points

**Note:** Horizontal ceiling hung or floor mount available – see [EH/SEH brochure](#).

**Please note:** Optional equipment may impact overall dimensions and weight. Please request submittal drawing from factory.

## Available Accessories

**Wall Shelf:** A wall shelf is available for 6–40 gallon models only, to order specify part number "WALL SHELF"

**10-year Warranty:** 10-year non pro-rated tank warranty, specify part number "VESSEL WARRANTY"

*Fill out form below to order accessories.*

**Accessories Name** \_\_\_\_\_ **Part #** \_\_\_\_\_

**Accessories Name** \_\_\_\_\_ **Part #** \_\_\_\_\_